

PRODUCT DISCRPTION

MODEL NO.: VC-0327, VC-0334, VC-0342, VC-0348

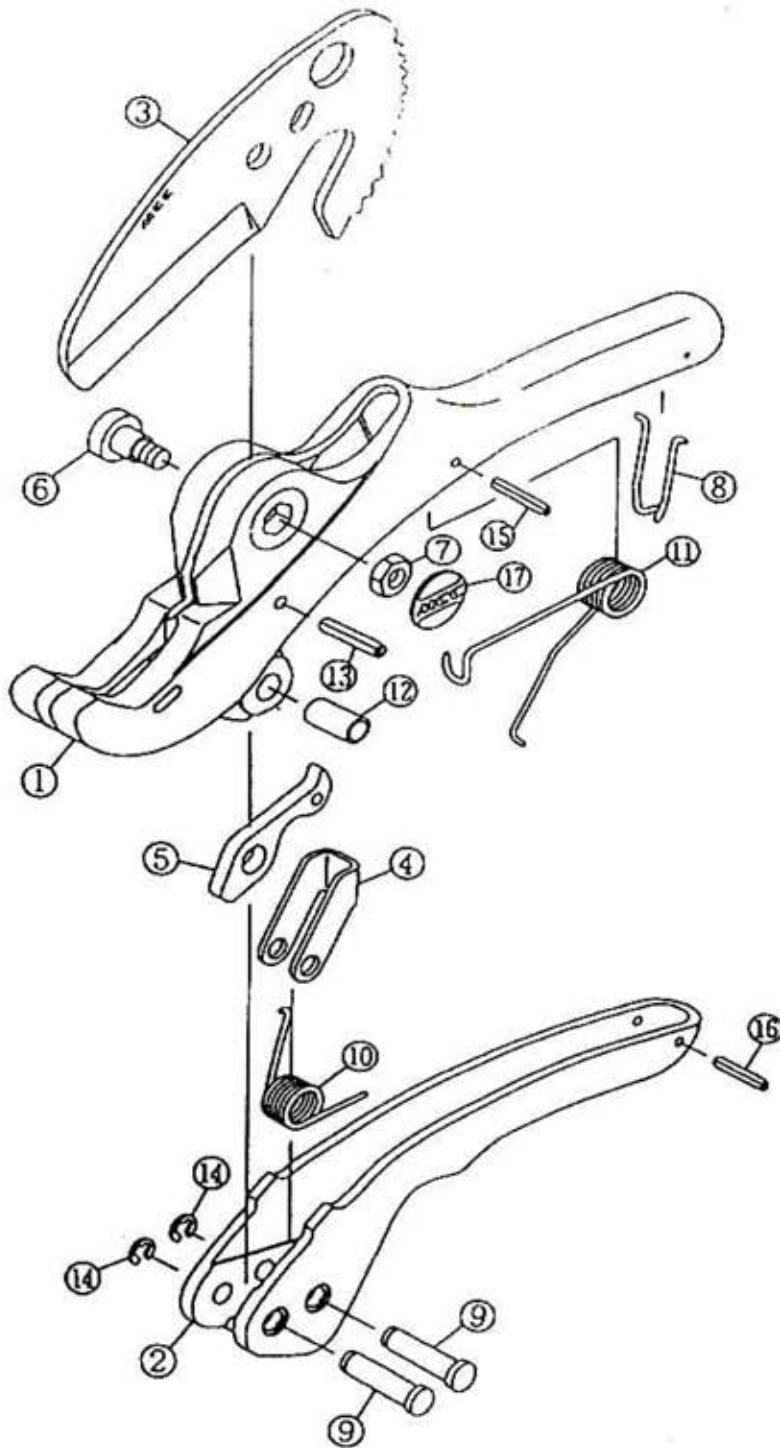

No.	Parts	Qty
1	Handle (Right)	1
2	Handle (Left)	1
3	Blade	1
4	Ratchet	1
5	Pawl	1
6	Bolt	1
7	Nut	1
8	Hook	1
9	Pin	2
10	Coil Spring (S)	1
11	Coil Spring (L)	1
12	Bushing	1
13	Spring Pin (D4x20)	1
14	E-Ring	2
15	Spring Pin (D3x20)	1
16	Spring Pin (D3x17)	1
17	Sticker	1

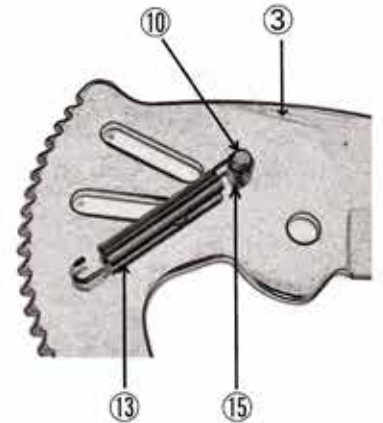
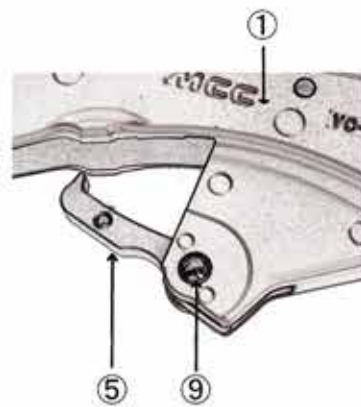
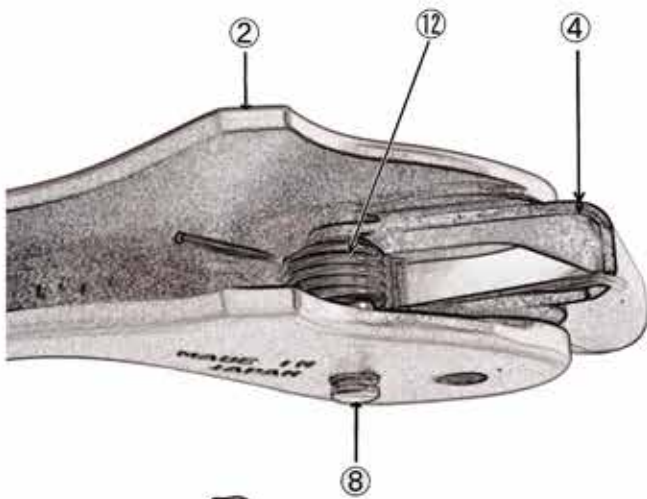
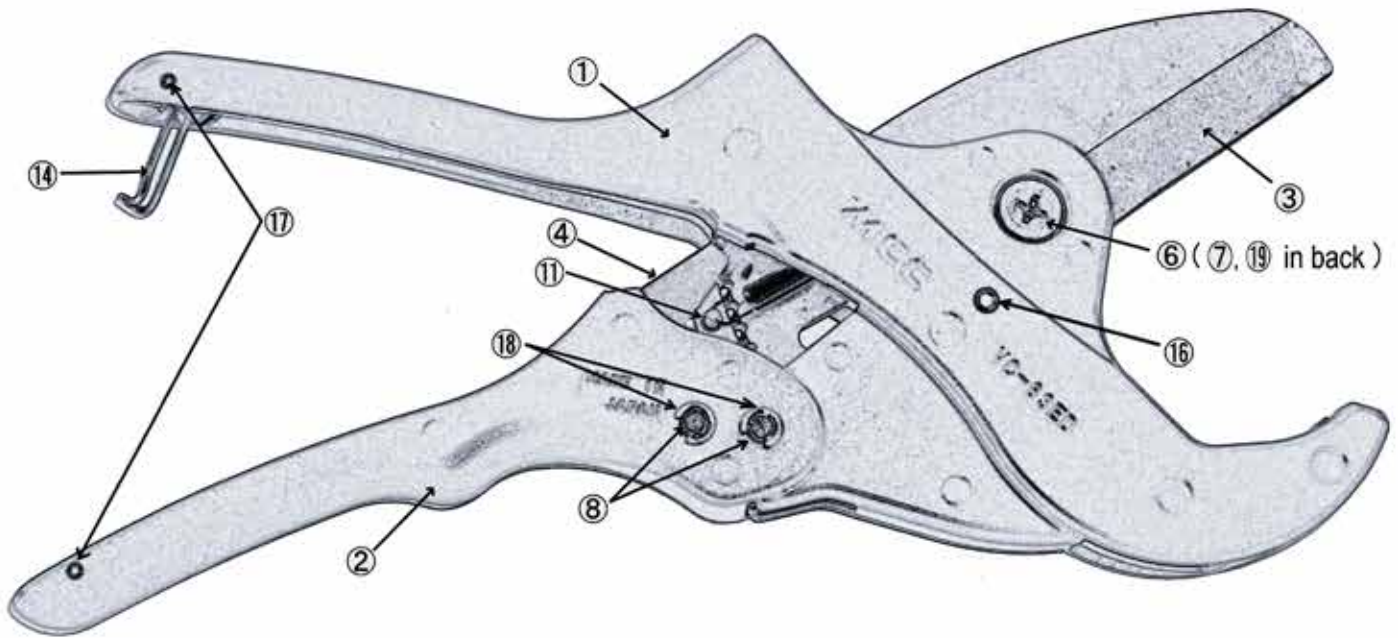

NO.	PART NAME	NO.	PART NAME
1	Handle(Right)	11	Pin(2)
2	Handle(Left)	12	Coil Spring
4	Ratchet	13	Pulled Coil Spring
5	Pawl	14	Hook
6	Bolt for Blade	15	Spacer
7	Lock Nut	16	Spring Pin (D5*22)
8	Pin	17	Spring Pin (D3*17)
9	Bushing	18	E-Ring
10	Pin(1)	19	MCC Sticker